



Committing to the future

testo 6440

Compressed Air Counter testo 6440

Saving costs with consumption measurement

NEW!

Nm³/h

Nl/min

Nm³



Saving compressed air costs with testo 6440

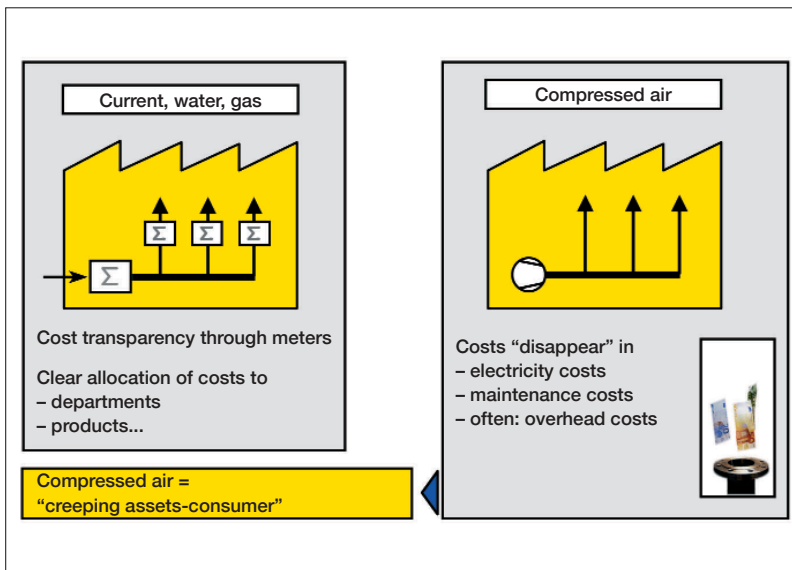

Why does industry need compressed air counters?

For media such as current, water or gases, complete transparency is guaranteed in every industrial company: Central counters reflect the quantities used; decentralized counters show how consumption is distributed.

The medium compressed air however, is produced and distributed internally, without knowing how much is used in total and in the individual departments. Without this knowledge, there is no motivation to eliminate leakages or achieve more economical use.

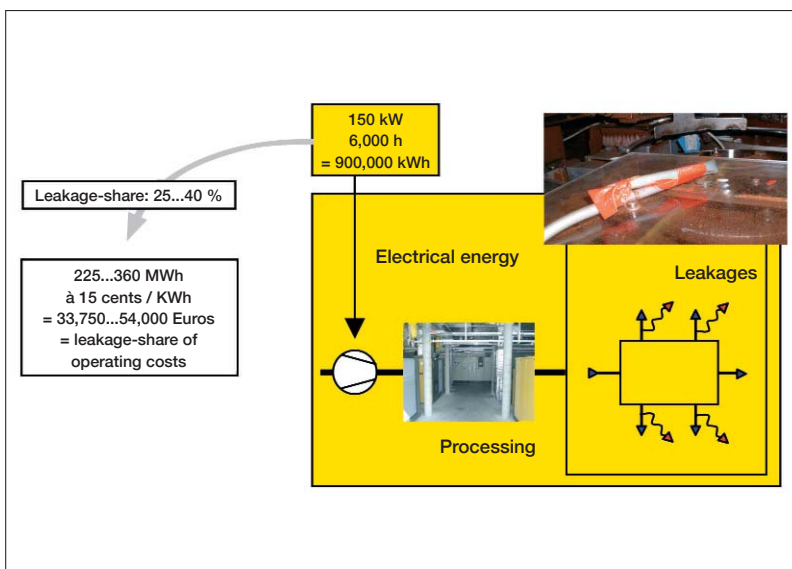

Leakage - a high cost factor

Independent investigations, for example by the Fraunhofer Institute in the course of the measurement campaign "Compressed air efficiency", have proven that between 25 and 40% of compressed air produced is wasted through leakage. Leakage holes with a diameter of 3 mm already lead to costs amounting to 3,000 Euro/annum.

If the necessary extra investments are added to the operating costs, the wastage adds up to over 100,000 Euros per year in an average industrial company.

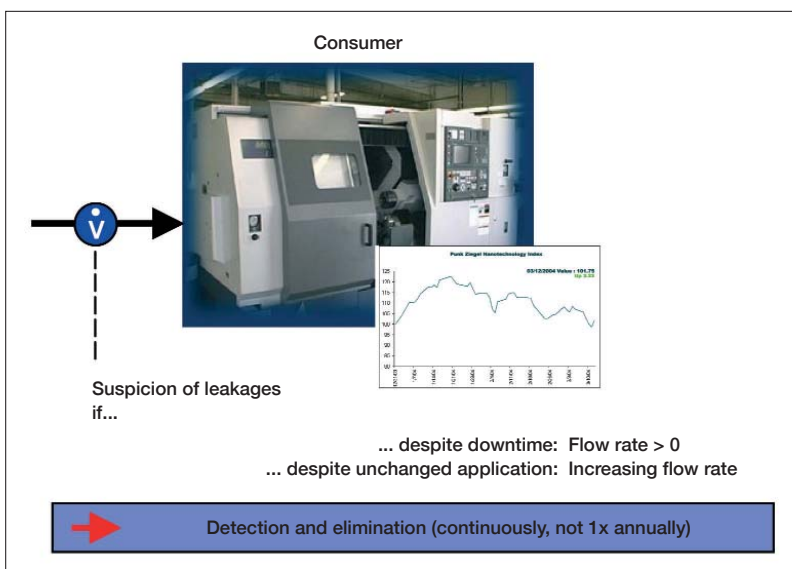

Leakage detection with the testo 6440

Over 96% of leakages occur in pipes DN50 and smaller. Leaky hoses, fittings, couplings and maintenance units are mainly responsible for this.

Installed in front of a machine or a machine group, the testo 6440 detects the smallest compressed air volume flows. These indicate leakages if they occur when the system is inactive.

It is also an indicator for leakage when known max.-volume flows are exceeded when the user profile is unchanged. The integrated switch outputs of the testo 6440 are thus the best leakage detector in practice.

Saving compressed air costs with testo 6440

Lowering costs by consumer-allocation

Compressed air is a profitable, but also very costly energy source. If the high costs are only allocated as a “cost block”, those responsible for the systems have no motivation to try and lower costs.

However, if the compressed air consumption of each system is recorded individually, the person responsible for the system is motivated to reduce leakage and to employ consumption-saving measures.

The testo 6440 provides optimal support here, in that it has a built-in totaliser function. The total consumption can be read directly from the instrument or registered in the regulating system via consumption impulses. Consumption-dependant switch outputs are alternatively also available, which can monitor consumption dependantly or independantly of time.

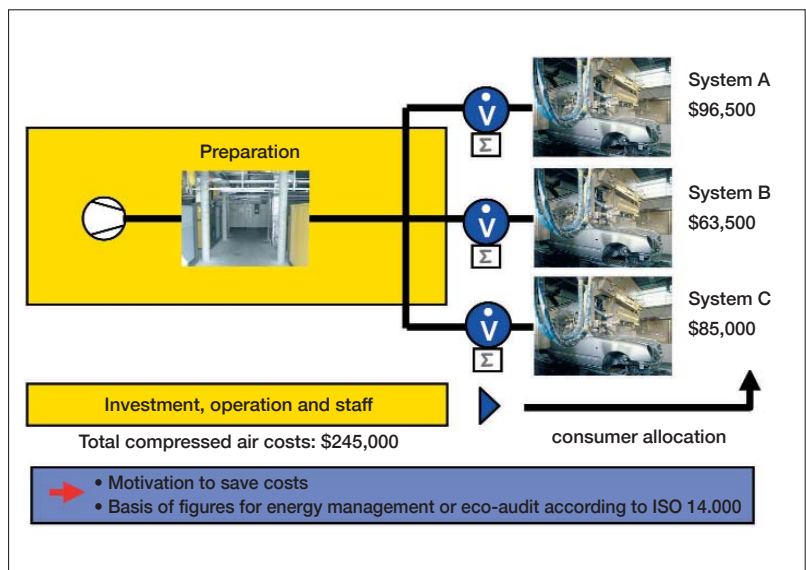

Peak load management helps to avoid extended investments

Growth can be expensive: Expanding industrial enterprises (example: new system D) are forced to expand their compressed air production too.

A peak load analysis on the basis of compressed air counters helps to avoid such investments. Since it is known when which consumption occurs, the distribution can be specifically regulated so that the existing capacity of compressed air production is sufficient. The result is considerable savings in the compressors as well as in the pipe system.

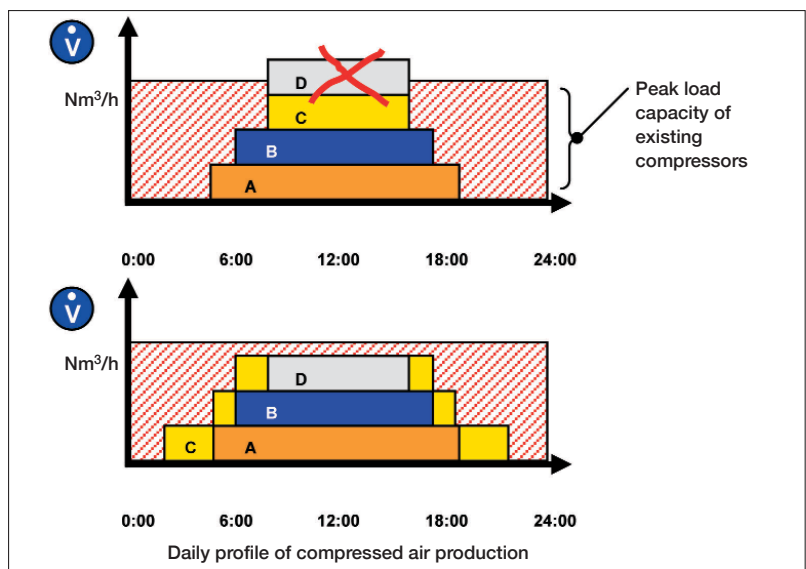

Protecting valuable compressed air consumers from too high or too low supply

Compressed air consumers require a minimal supply in order to provide the desired performance.

Some consumers additionally have to be protected from too high a supply. In some cases, the warranty of the system's manufacturer is even dependant on this.

The testo 6440 performs both tasks optimally thanks to its two switch outputs. For the continuous protection of your investment.

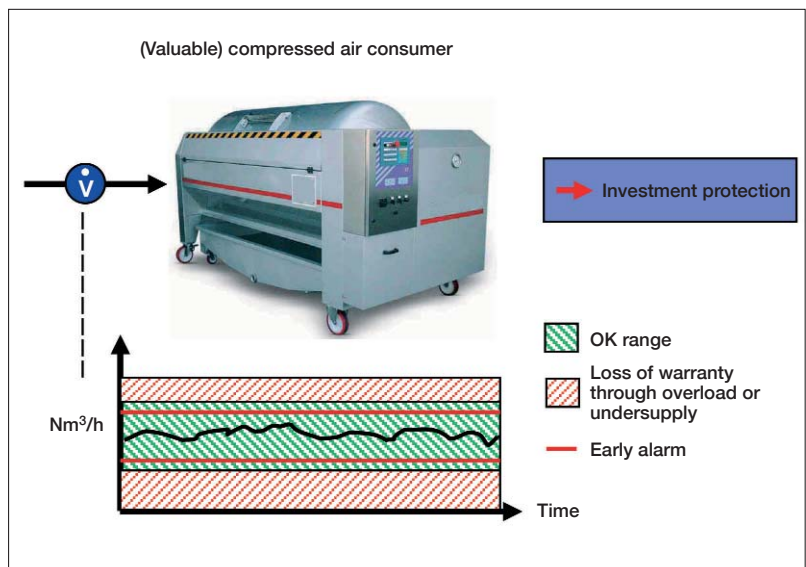

Compressed air counter testo 6440: The measurement principle

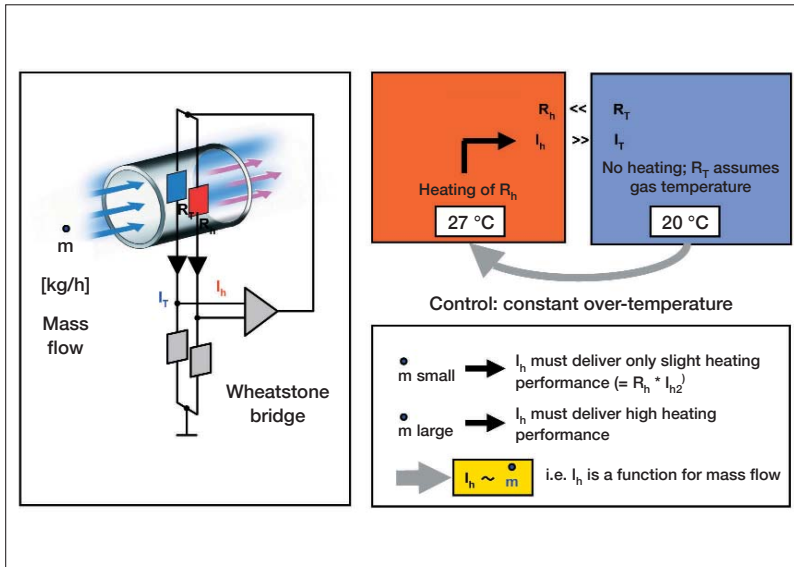

The optimal measurement principle...

...for compressed air norm volume flow measurement is thermal mass flow measurement. Only this

- is independent of process pressure and temperature
- causes no permanent loss of pressure

Two glass-coated ceramic sensors developed specially for demanding compressed air application are exposed to the process temperature and switched with a Wheatstone bridge.

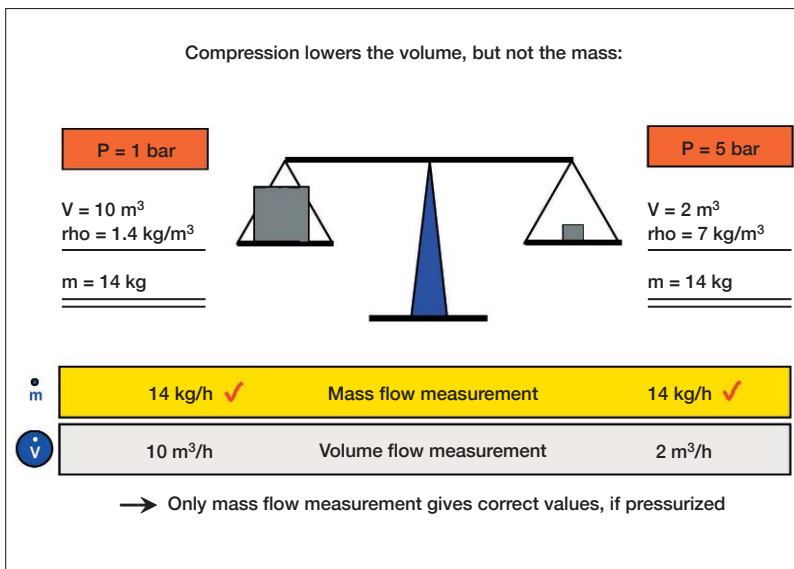

Why is the measurement of mass flow pressure and temperature independent?

Volume is compressed with rising pressure. The mass, however, remains unchanged, as the adjacent ill. shows. It follows that only mass flow measurement is suitable for use in fluctuating pressure conditions. An influencing by the temperature can also be avoided by means of a compensation. This way, the measurement value can be used optimally in the entire range of process temperature.

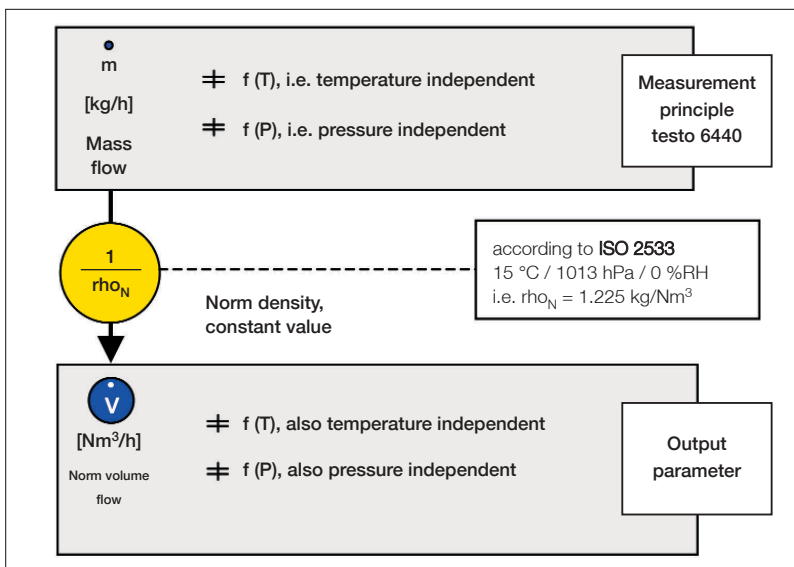

How does mass flow become norm volume flow?

For the compressed air consumer, norm volume flow is the most important flow function. It refers not to the current ambient conditions, but to fixed values; according to ISO 2533, these are the values 15 °C / 1013 hPa / 0 %RH. The testo 6440 divides the mass flow value by the norm density, which is generally 1.225 kg/Nm³. The result is the pressure and temperature independent norm volume flow value. When comparing measurements made with other measurement systems, it must be ensured that all values refer to the same norm conditions; otherwise a conversion calculation is necessary.

Compressed air counter testo 6440: Instrument and features

For all important diameters: the compressed air counter testo 6440

In four diameter sizes, the testo 6440 offers a compact design coupled with integrated high-performance technology, which provides all necessary signal outputs.

The built-in inflow and outflow pipes allow optimum accuracy.

The thermal, glass-coated ceramic sensor offers robustness at the same time as fastest reaction times.

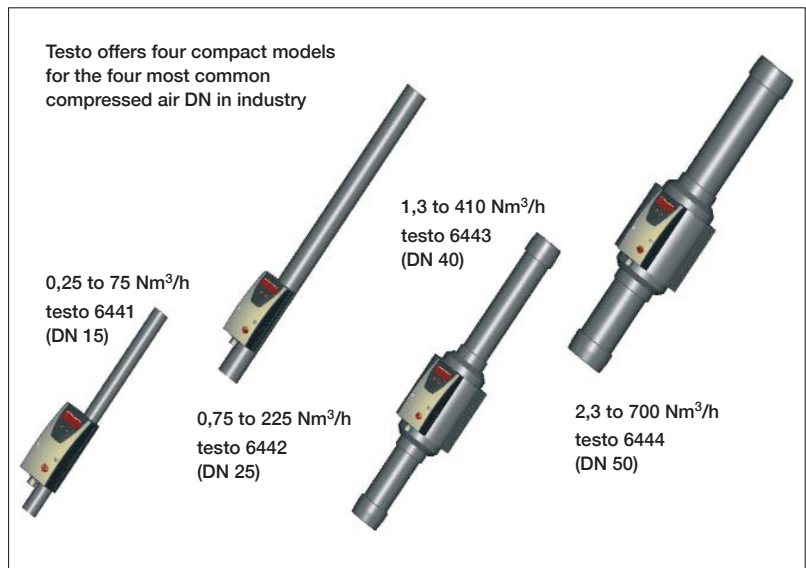

Superior design from the sensor to the housing

In contrast to the penetration probes used by competitors, the sensor in the testo 6440 has a position in the pipe which is exactly known and always the same. With penetration probes, a tilt out of the vertical of 5° already leads to a measurement inaccuracy of 5%.

In the testo 6440, not only are the inflow and outflow pipes integrated, they also have completely even surfaces (i.e. no flange recesses etc.)

Many clever details in the design of testo 6440 ensure that the flow profile remains constant and that an optimum of accuracy can be achieved.

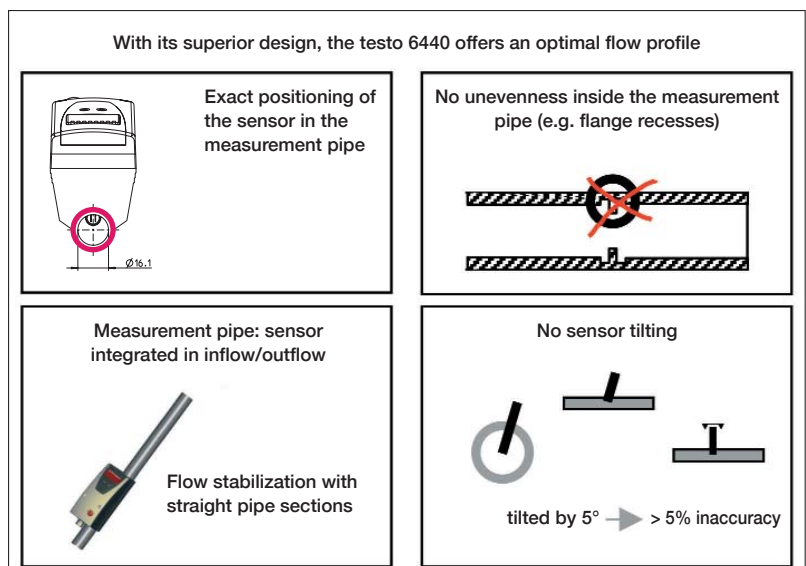

Defined interior diameter and volume flow adjustment for highest accuracy

Especially in small diameters, the exact knowledge of the interior diameter plays a deciding part in achieving accurate measurements of norm volume flow.

Commercially available penetration probes measure the flow velocity and calculate the volume flow by multiplication with the cross-section area. As shown in the illustration, even normed pipes can vary in interior diameter to such a degree that inaccuracies of up to 33% are possible.

The testo 6440 has an exactly known diameter – and is adjusted directly according to norm volume flow, and not flow velocity!

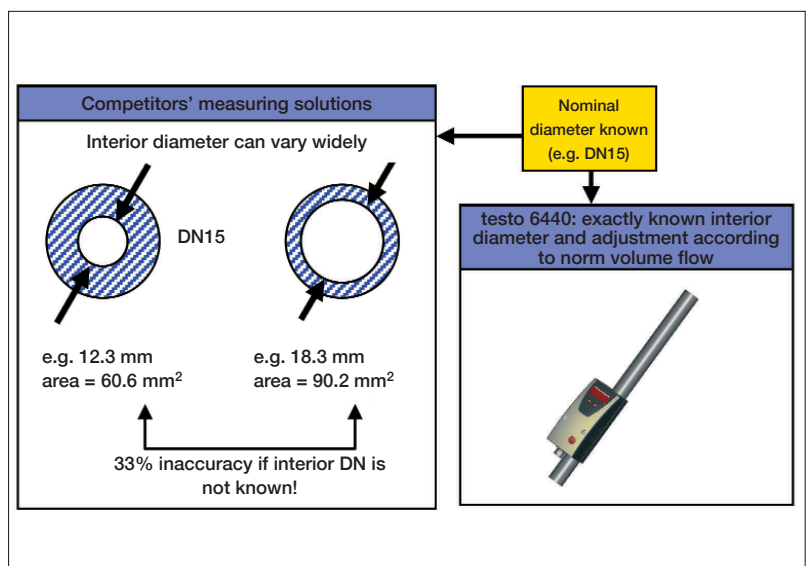

Compressed air counter testo 6440: Dimensional drawing

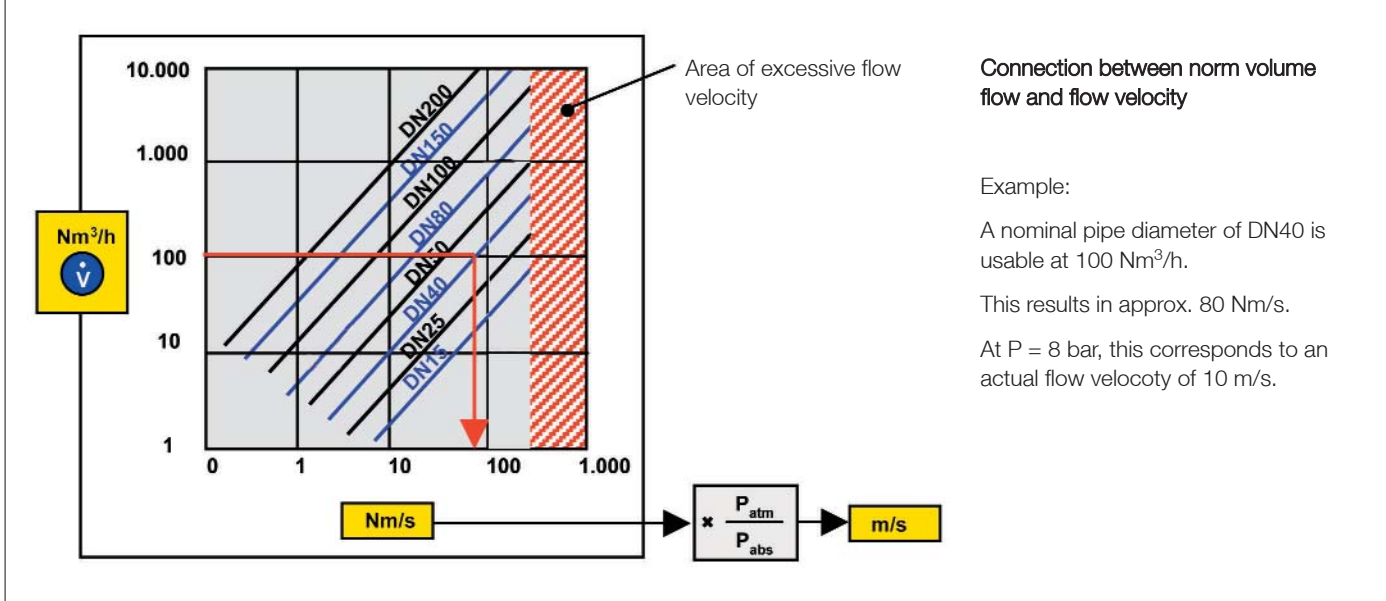
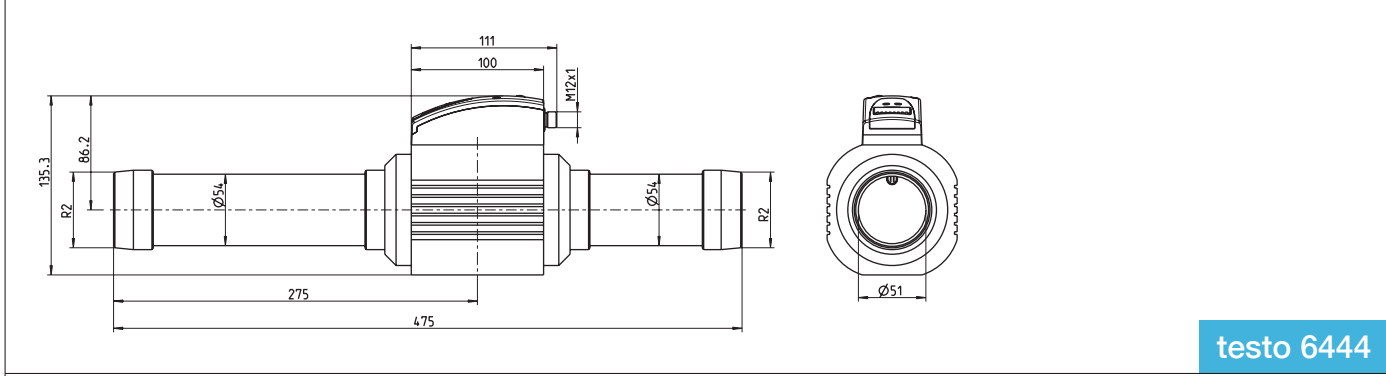
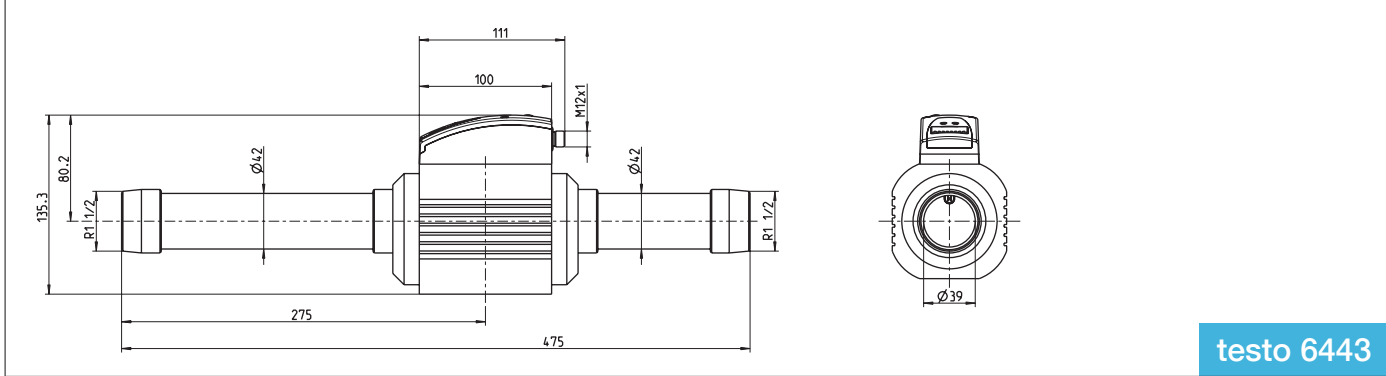
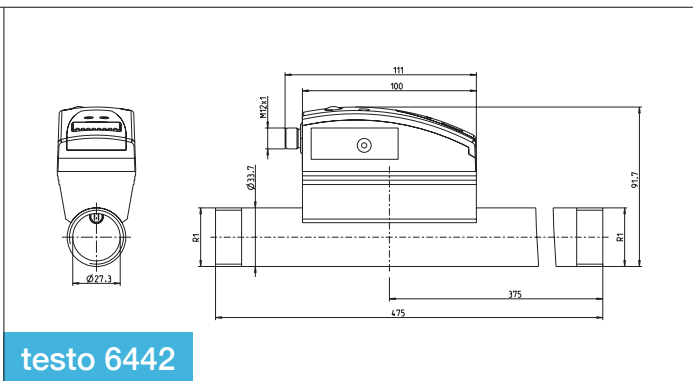
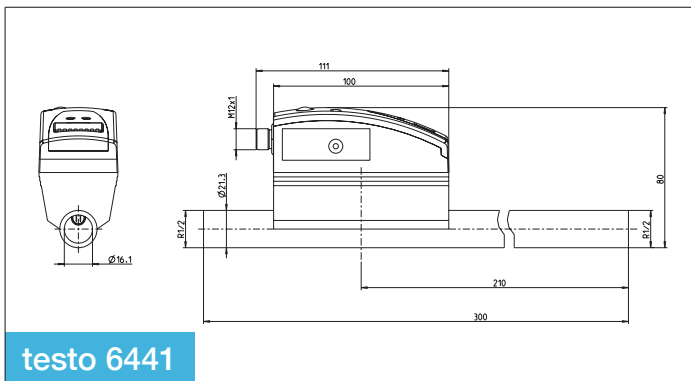



Compressed air counter testo 6440: Technical data and ordering data

Technical data compressed air counter testo 6440				
	testo 6441	testo 6442	testo 6443	testo 6444
Part no.	0555 6441	0555 6442	0555 6443	0555 6444
Pipe diameter	DN 15 (for 1/2" pipes)	DN 25 (for 1" pipes)	DN 40 (for 1 1/2" pipes)	DN 50 (for 2" pipes)
Measuring range (1:300)	0.25 to 75 Nm ³ /h	0.75 to 225 Nm ³ /h	1.3 to 410 Nm ³ /h	2.3 to 700 Nm ³ /h
Max. display value	90 Nm ³ /h	270 Nm ³ /h	492 Nm ³ /h	840 Nm ³ /h
Measuring stretch: Thread (both sides) / Material	R 1/2, Stainless steel 1.4301	R1, Stainless steel 1.4301	R1 1/2, Stainless steel 1.4401	R2, Stainless steel 1.4401
Length measurement pipe	300 mm	475 mm	475 mm (shortened measurement stretches)	475 mm (shortened measurement stretches)
Weight	0.9 kg	1.1 kg	3.0 kg	3.8 kg
Sensor	Thermal glass-coated ceramic sensor			
Accuracy	for compressed air quality classes (ISO 8573: particles – humidity – oil) 1-4-1: ±3% of reading ±0.3% of final value for compressed air quality classes (ISO 8573: particles – humidity – oil) 3-4-4: ±6% of reading ±0.6% of final value			
Reaction time	< 0.1 sec (for damping parameter = 0), delayable via operating menu (0 s to 1 s)			
Temperature display	0 ... +60 °C, inaccuracy ±2K			
Display, operation	4-figure alpha-numeric display, two operation buttons, operating menu, LED (4x green for phys. units, 3x yellow for "display x 1,000" or switch status)			
Display units	Nm ³ /h, NI/min, Nm ³ , °C (selected unit displayed by green LED)			
Electrical connection	M12x1 plug, load to 250 mA, short circuit-proof (synchronized), reverse polarity-proof, overload-proof. Testo recommends the accessory cable Order No. 0699 3393			
Voltage supply	19...30 VDC, current consumption < 100 mA			
Output signals	Via operating menu, 4 combination are parameterable, see p. 6			
Pulse output	Consumption counter (value available after reset or voltage loss due to non-deleting store), value 0.001...1,000,000 m ³ , pulse length 0.02 s ... 2 s, 24 VDC level			
Analog output	4...20 mA (4-wire), max. load 500 Ohm, freely scalable from 0 to end of measuring range			
Switch output	2 switch outputs, parameterable, (dependent on consumption or volume flow, time-dependent/independent, opener, closer, hysteresis, window), loadable with max. 19...30 VDC or 250 mA each, switch status is displayed via 2 LEDs			
Process conditions	0...+60 °C, PN 16, rel. humidity < 90 %RH, air quality ISO 8573: recommended classes 1-4-1			
Ambient temperature	0...+60 °C			
Storage temperature	-25...+85 °C			
Media contact	Materials stainless steel 1.4301 or 1.4401 (s. above, Material), PEEK, polyester, viton, anodized aluminium, ceramics			
Housing	PBT (GF 20%), zinc diecast, IP65 / III			
EMC	In accordance with guideline 89/336 EWG			
Ordering data				Part no.
testo 6441 Compressed air counter DN 15				0555 6441
testo 6442 Compressed air counter DN 25				0555 6442
testo 6443 Compressed air counter DN 40				0555 6443
testo 6444 Compressed air counter DN 50				0555 6444
Connection cable 5 m length, with M12x1 socket / open wire ends				0699 3393
External testo 54 – 2 AC display, 2 relay outputs (up to 300 VAC, 3 A), 230 VAC				5400 7553
External testo 54 – 7 AC display, 2 relay outputs (up to 300 V AC, 3 A), 90...260 V AC, RS485 output for online monitoring				5400 7555
Mains unit (desk-top) 110 to 240V AC/24V DC (350mA)				0554 1748
Mains unit (rail mounting) 90 to 264V AC/24V DC (2.5A)				0554 1749
ISO calibration at 5 measurement points, to 250 Nm ³ /h (testo 6441 / 6442)				0520 0174
DKD calibration at 5 measurement points, to 250 Nm ³ (testo 6441 / 6442)				0520 0274
ISO calibration at 5 measurement points, to 1600 Nm ³ /h (testo 6443 / 6444)				0520 0184
DKD calibration at 5 measurement points, to 1600 Nm ³ /h (6443 / 6444)				0520 0284